

Globe Valves

Type 01301 - Globe Valve



Cryogenic-Globe and Globe/Check Valves, PN50 (DN10-25), PN40 (DN32), PN35 (DN40-50)

- Bronze body and topwork
- "live loaded" gland packing
- "cleaned and degreased for oxygen service"

Part No. 01301.X.0008

Part No. 01301.X.5008 Globe/Check Valve

Complete with brazed copper stubs acc. to DIN EN 12449

Available options - on request only:

- Valve with control disc (tapered design)

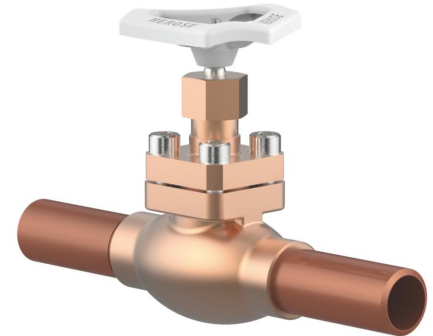

Applications:

Approved for air gases, vapours and cryogenic liquefied gases incl. LNG.

Working temperature: - 196°C / -321°F (77K) up to +120°C / +248°F (393K)

Recommended working temperature: -60°C / -76°F (213K) up to +120°C / +248°F (393K)

Materials	DIN EN	ASTM
1 Body	CC491K	B 62 UNS C83600
2 Valve seal	PTFE / Carbon filled (25%)	
3 Disc	CW614N	B 283 UNS C38500
4 Bonnet gasket	PTFE	
5 Headpiece	CC493K	B 505 UNS C93200
6 Bolts	1.4301/A2 A 194 B8	
8 Stem	1.4301 A 276 Grade 304	
9 Gland packing	Graphite / PTFE	
10 Gland nut	CW614N	B 283 UNS C38500
11 Handwheel	Aluminium alloy	
12 Spring	CW452K	B 159 UNS C51900
13 Copper stubs	CW024A	B 152 UNS C12200

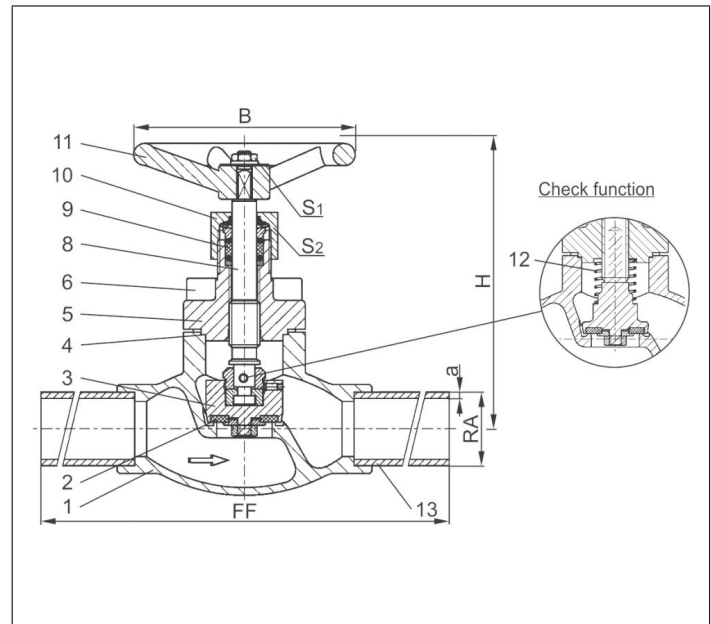

Type 01301 - Standard design	Technical data								
Nominal size	DN	10	15	15	20	25	32	40	50
Dimension code	.X.	1012	1515	1518	2022	2528	3235	4042	5054
Face-to-face dimension	FF	360	385	385	385	415	415	420	460
Height	H	140	140	140	140	140	170	175	200
Outside pipe-Ø	RA	12.0	15.0	18.0	22.0	28.0	35.0	42.0	54.0
Wall thickness pipe	a	1.0	1.5	1.5	1.5	1.5	1.5	1.5	2.0
Handwheel-Ø	B	100	100	100	100	100	125	125	125
Wrench size across flats	S ₁	7	7	7	7	7	10	10	10
Wrench size across flats	S ₂	30	30	30	30	30	36	36	36
Weight	ca. kg	1.1	1.4	1.4	1.8	2.4	3.2	4.8	7.5
Kvs-Value	m ³ /h	2.2	4.3	4.3	6.7	11.5	12.1	22.6	37.1
Cv-Value	gal/min	2.6	5.0	5.0	7.8	13.4	14.1	26.3	43.2

Dimensions in mm.