

Globe Valves

Type 01305 - Globe Valve



Cryogenic-Globe and Globe/Check Valves, PN50

- Bronze body and topwork
- "live loaded" gland packing
- "cleaned and degreased for oxygen service"

Part No. 01305.X.0001

Part No. 01305.X.5001 Globe/Check Valve

Female thread connection (G) acc. to ISO 228/1

Part No. 01305.X.0006

Part No. 01305.X.5006 Globe/Check Valve

Female thread connection NPT acc. to ANSI B 1.20.1

Available options - on request only:

- Female thread connection (R) acc. to ISO 7-Rc
- Valve with control disc (tapered design)

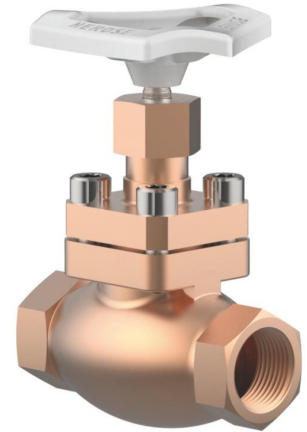

Applications:

Approved for air gases, vapours and cryogenic liquefied gases incl. LNG.

Working temperature: -196°C / -321°F (77K) up to +120°C / +248°F (393K)

Recommended working temperature: -60°C / -76°F (213K) up to +120°C / +248°F (393K)

Materials	DIN EN	ASTM
1 Body	CC491K	B 62 UNS C83600
2 Valve seal	PTFE / Carbon filled (25%)	
3 Disc	CW614N	B 283 UNS C38500
4 Bonnet gasket	PTFE	
5 Headpiece	CC493K	B 505 UNS C93200
6 Bolts	1.4301/A2 A 194 B8	
8 Stem	1.4301 A 276 Grade 304	
9 Gland packing	Graphite / PTFE	
10 Gland nut	CW614N	B 283 UNS C38500
11 Handwheel	Aluminium alloy	
12 Spring	CW452K	B 159 UNS C51900

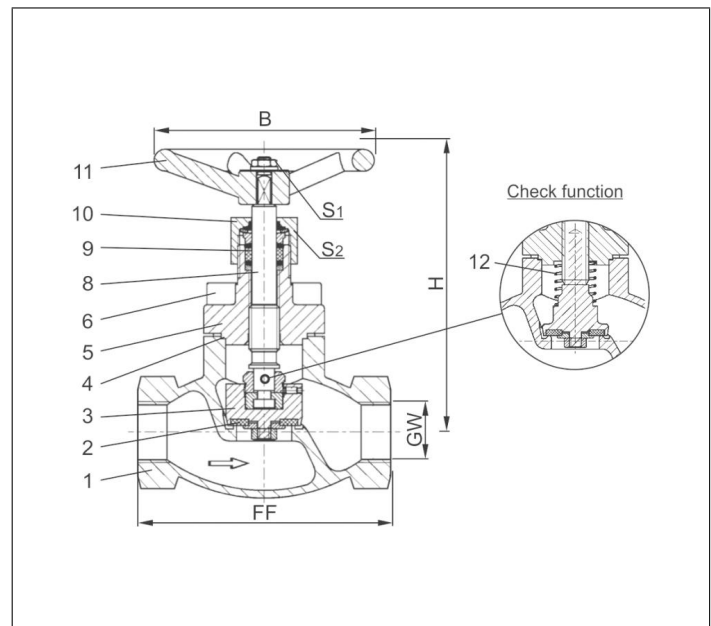

Type 01305 - Standard design	Technical data								
Nominal size	DN	10	10	15	20	25	32	40	50
Thread size	GW	1/4	3/8	1/2	3/4	1	1-1/4	1-1/2	2
Dimension code	.X.	0200	0300	0400	0600	1000	1200	1400	2000
Face-to-face dimension	FF	60	60	85	85	115	115	140	160
Height	H	140	140	140	140	140	170	175	200
Handwheel-Ø	B	100	100	100	100	100	125	125	125
Wrench size across flats	S ₁	7	7	7	7	7	10	10	10
Wrench size across flats	S ₂	30	30	30	30	30	36	36	36
Weight	ca. kg	1.0	1.0	1.3	1.7	2.0	2.8	4.2	6.7
Kvs-Value	m ³ /h	1.6	2.2	4.3	6.7	11.5	20.6	22.6	37.1
Cv-Value	gal/min	1.9	2.6	5.0	7.8	13.4	23.9	26.3	43.2

Dimensions in mm.