

Angle Valves

Type 01332 - Globe Valve Angle Type



Cryogenic-Globe Valves Angle Type, PN50

Stainless steel body and bronze topwork,
 "live loaded" Stainless steel body and bronze topwork,
 "cleaned and degreased for oxygen service"

Part No. 01332.X.000*

* Butt weld connection for stainless steel pipes acc. to ISO 1127 or ASTM A312

Part No. 01332.X.0004

Socket weld connection for stainless steel pipes acc. to ISO 1127 or ASTM A312

Available options - on request only:

- Valve with control disc (tapered design)
- Valve with check disc
- Further pipe wall thicknesses

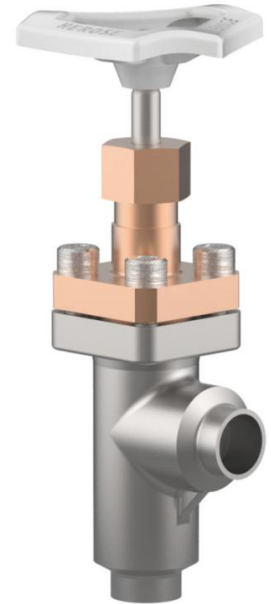

Applications:

Approved for air gases, vapours and cryogenic liquefied gases incl. LNG.

Working temperature: -196°C / -321°F (77K) up to +120°C / +248°F (393K)

Recommended working temperature: -60°C / -76°F (213K) up to +120°C / +248°F (393K)

Materials	DIN EN	ASTM
1 Body	1.4308	A 351 CF8
2 Valve seal	PTFE / Carbon filled (25%)	
3 Disc	CW614N	B 283 UNS C38500
4 Bonnet gasket	PTFE	
5 Headpiece	CC493K	B 505 UNS C93200
6 Bolts	1.4301/A2	A 194 B8
7 Stem	1.4301	A 276 Grade 304
9 Gland packing	Graphite / PTFE	
10 Gland nut	CW614N	B 283 UNS C38500
11 Handwheel	Aluminium alloy	

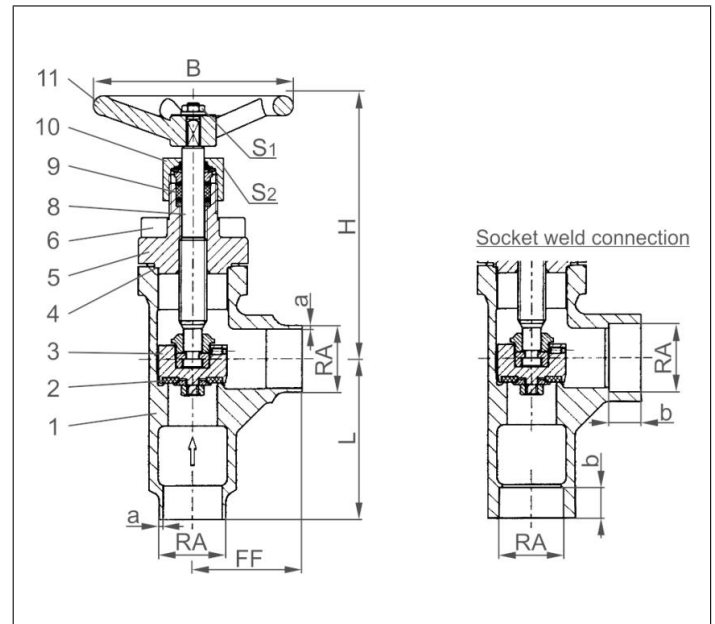

Type 01332 - Standard design	Technical data						
Nominal size	DN	15	20	25	32	40	50
Dimension code	.X.	1521	2026	2533	3242	4048	5060
Face-to-face dimension	FF	40	50	55	60	58	85
Height	H	140	140	140	170	175	200
Outside pipe-Ø ISO 1127	RA	21.3	26.9	33.7	42.0	48.3	60.3
Wall thickness pipe ISO 1127	a	2.0	2.0	2.0	2.0	2.0	2.0
Outside pipe-Ø ASTM A312	RA	21.34	26.67	33.4	-	48.26	60.33
Wall thickness pipe ASTM A312	a	dimensions acc. to S10 or S40					
Socket depth	b	10	13	13	13	13	16
Handwheel-Ø	B	100	100	100	125	125	125
Length	L	50	65	80	80	90	90
Wrench size across flats	S ₁	7	7	7	10	10	10
Wrench size across flats	S ₂	30	30	30	36	36	36
Weight	ca. kg	1.0	1.3	1.7	3.1	3.3	6.0
Kvs-Value	m ³ /h	6.0	10.5	17.2	32.0	35.0	57.0
Cv-Value	gal/min	7.0	12.2	20.0	37.2	40.7	66.3

Dimensions in mm.