

Actuated Valves and Actuators

Type 01423 - Actuated Globe Valve T-Model



Top Entry Cryogenic-Globe Valves with Pneumatic Actuator, PN50

Stainless steel body and topwork

"live loaded" gland packing

"cleaned and degreased for oxygen service" - the actuator is not cleaned and degreased for oxygen

Part No. 01423.XC3C22 (DN15, DN25)

Part No. 01423.XC3C32 (DN40, DN50)

Available accessories/options - on request only:

- Solenoid valve · Limit switch · Electropneumatic positioner etc.
- Extension H and A acc. to customer specification
- Actuator "cleaned and degreased for oxygen service"
- Valve with check disc, valve with control disc (tapered design)



Applications:

Approved for air gases, vapours and cryogenic liquefied gases.

Working temperature: -196°C / -321°F (77K) up to +120°C / +248°F (393K)

Materials	DIN EN	ASTM
1 Body	1.4308	A 351 CF8
2 Valve seal	PTFE / Carbon filled (25%)	
3 Disc	1.4301	A 276 Grade 304
4 Guide bush	PTFE	
5 Stem	1.4301	A 276 Grade 304
6 Tube	1.4301	A 276 Grade 304
7 Headpiece flange	1.4301	A 276 Grade 304
8 Cold box feature	1.4301	A 276 Grade 304
9 Bolts	A2-70	B8
10 Gland packing	Graphite / PTFE / Mica	
11 Gland nut	1.4404	A 276 Grade 316L

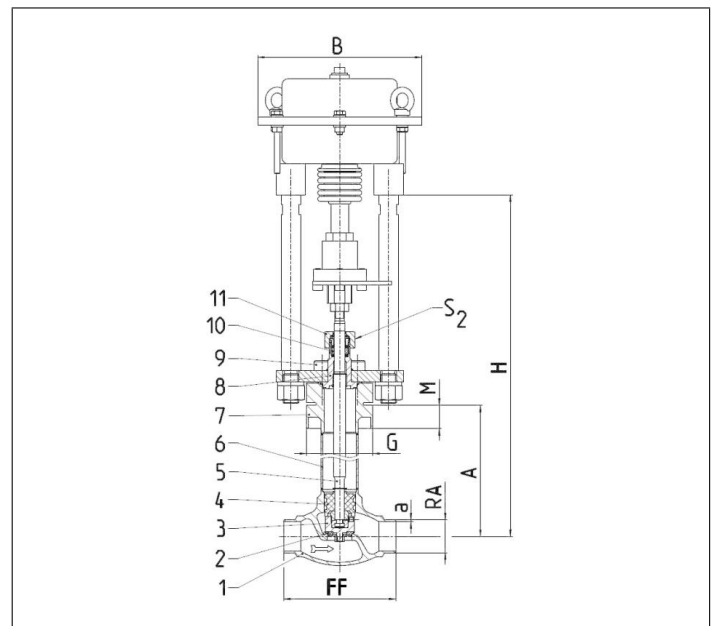

Type 01423 - T-Model	Technical data				
Nominal size	DN	15	25	40	50
Dimension code	.X.	1521	2533	4048	5060
Face-to-face dimension	FF	135	165	180	205
Height	H	526	506	644	649
Actuator-Ø	B	dependent on actuator			
Outside pipe-Ø ASTM A312	RA	21.34	33.40	48.26	60.33
Wall thickness pipe ASTM A312	a	dimensions acc. to S10 or S40			
Length	A	290	290	351	351
Length	G	68	68	109	134.5
Length	M	14	24	19	22
Wrench size across flats	S ₂	27	27	32	32
Weight without actuator	ca. kg	3.6	4.2	9.3	12.8
*Kvs-Value	m ³ /h	4.3	11.5	22.6	37.1
*Cv-Value	gal/min	5.0	13.4	26.3	43.2
Stroke	mm	10	9	11	15

Dimensions in mm. * These figures refer to measurements for the flow direction.