

Fire Safe Valves

Type 01653 - Actuated Trailervalue



Cryogenic-Globe Valves with Pneumatic Actuator, PN50

“Fire safe” type test approval acc. to EN ISO 10497

air pressure for operation 6.0 bar g (maximum 10.0 bar g), push-in connection 8mm

Stainless steel body and topwork,

Actuator - air opens, spring closes

“live loaded” gland packing

“cleaned and degreased for oxygen service” - the actuator is not cleaned and degreased for oxygen

maximum working pressure of the valve depending on nominal size

Part No. 01653.X.T0**

* Butt weld connection for stainless steel pipes acc. to ISO 1127 or ASTM A312

Part No. 01653.X.T0*4

Socket weld connection for stainless steel pipes acc. to ISO 1127 or ASTM A312

Available options - on request only:

- Welded stainless steel stubs acc. to ISO 1127 or ASTM A312 - length FF + 200mm
- Weather protection hood



Applications:

Approved for air gases, vapours and cryogenic liquefied gases incl. LNG.

Working temperature: -196°C / -321°F (77K) up to +120°C / +248°F (393K)

Ambient temperature actuator: -50°C / -58°F (223K) up to +70°C / +158°F (343K)

Materials	DIN EN	ASTM
1 Body	1.4308	A 351 CF8
2 Valve seal	PTFE / Carbon filled (25%)	
3 Disc	1.4301	A 276 Grade 304
4 Bonnet gasket	Graphite	
5 Headpiece	1.4301	A 276 Grade 304
6 Bolts	1.4301/A2	A 194 B8
7 Elongation tube	1.4306	A 213 TP 304L
8 Stem	1.4301	A 276 Grade 304
9 Spring	1.4571	A 313 Grade 316Ti
10 Flansch	1.4301	A 276 Grade 304
11 Headpiece	1.4301	A 276 Grade 304
12 Gland packing	Graphite / PTFE / MICA	
13 Gland nut	1.4571	A 313 Grade 316Ti
14 Pillars	1.4301	A 276 Grade 304
15 Bush	CW452K	B 159 UNS C51900
16 Actuator	Rubber	

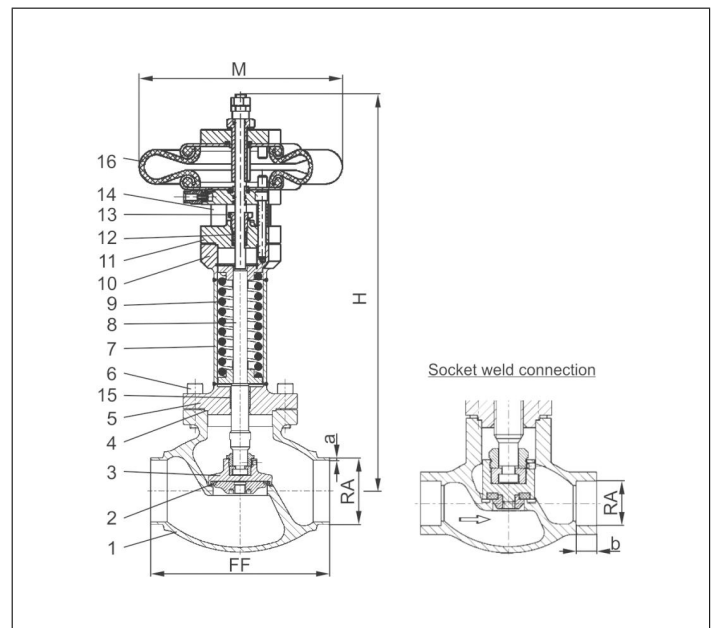

Type 01653 - Standard design	Technical data									
	Nominal size	DN	20	20	25	40	40	50	65	80
Dimension code	.X.	2021	2026	2533	4042	4048	5060	657x	8088	
Face-to-face dimension	FF	100	100	115	130	130	155	205	245	
Height	H	443	443	444	441	441	420	448	467	
Outside pipe-Ø ISO 1127	RA	21.3	26.9	33.7	42.4	48.3	60.3	76.1	88.9	
Wall thickness pipe ISO 1127	a	2.0	2.0	2.0	2.0	2.0	2.0	2.9	3.2	
Outside pipe-Ø ASTM A312	RA	21.34	26.67	33.40	42.16	48.26	60.33	73.03	88.90	
Wall thickness pipe ASTM A312	a	dimensions acc. to S10 or S40								
Socket depth	b	10	10	13	13	13	16	16	16	
Actuator-Ø	M	229	229	229	229	229	229	229	229	
Weight	ca. kg	7.2	7.2	9.1	10.5	10.5	14.5	17.4	22.5	
*Kvs-Value	m ³ /h	4.3	4.3	11.5	22.6	22.6	37.1	71.1	104.0	
*Cv-Value	gal/min	5.0	5.0	13.4	23.9	26.3	43.2	82.9	121.3	
Stroke	mm	10	10	14	14	14	14	22	25	
Δ P max	bar	50	50	50	16	16	10	3	4	
Δ P max with special spring	bar	-	-	-	31	31	18	10	-	

Dimensions in mm. * These figures refer to measurements for the flow direction.