

# Globe Valves

## Type 02401 - Globe Valve



### Cryogenic-Globe and Globe/Check Valves, PN50

Bronze body and topwork,  
 "live loaded" gland packing  
 "cleaned and degreased for oxygen service"

**Part No. 02401.X.0001**

**Part No. 02401.X.5001 Globe/Check Valve**

Male thread for union connection

Available options - on request only:

- Valve with control disc (tapered design)

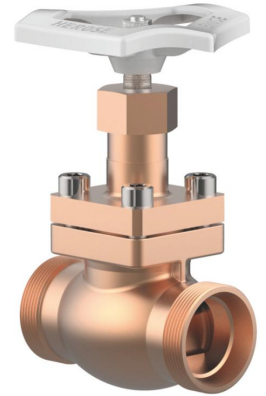

### Applications:

Approved for air gases, vapours and cryogenic liquefied gases incl. LNG.

Working temperature: -196°C / -321°F (77K) up to +120°C / +248°F (393K)

Recommended working temperature: -60°C / -76°F (213K) up to +120°C / +248°F (393K)

Materials	DIN EN	ASTM
1 Body	CC491K	B 62 UNS C83600
2 Valve seal	PTFE / Carbon filled (25%)	
3 Disc	CW614N	B 283 UNS C38500
4 Bonnet gasket	PTFE	
5 Headpiece	CC493K	B 505 UNS C93200
6 Bolts	1.4301/A2 A 194 B8	
8 Stem	1.4301 A 276 Grade 304	
9 Gland packing	Graphite / PTFE	
10 Gland nut	CW614N	B 283 UNS C38500
11 Handwheel	Aluminium alloy	
12 Spring	CW452K	B 159 UNS C51900

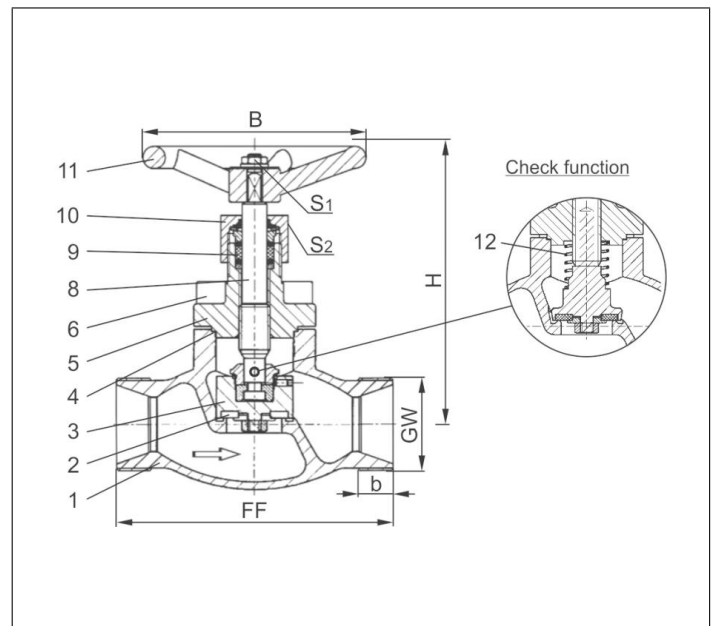

Type 02401 - Standard design	Technical data					
Nominal size	DN	10	20	32	40	50
Dimension code	.X.	0100	0200	0320	0400	0500
Face-to-face dimension	FF	60	85	115	140	160
Height	H	140	140	170	175	200
Union thread	GW	M26x1.5	M40x2.0	M55x2.0	M65x2.0	M78x2.0
Thread length	b	10	11	14	17	20
Handwheel-Ø	B	100	100	125	125	125
Wrench size across flats	S <sub>1</sub>	7	7	10	10	10
Wrench size across flats	S <sub>2</sub>	30	30	36	36	36
Weight	ca. kg	1.0	1.7	2.8	4.2	6.7
Kvs-Value	m <sup>3</sup> /h	2.2	6.7	12.1	22.6	37.1
Cv-Value	gal/min	2.6	7.8	14.1	26.3	43.2

Dimensions in mm.