

# Actuated Valves and Actuators

## Type 03343 - Actuated Globe Valve



### Cryogenic-Globe Valves with Pneumatic Actuator, class 150

Stainless steel body and topwork  
 Actuator - air opens, spring closes or contrary  
 "live loaded" gland packing

#### Part No. 03343.8000.X

Flanged connection acc. to ASME B16.5 class 300

In flow direction, the valve with the nominal size DN200 is conform to tightness class L1 up to 18 bar maximum differential pressure acc. to DIN 12567 for LNG use.  
 This standard can also be used for the tightness class of other cryogenic gases.

#### Available accessories:

- Solenoid valve
- Limit switch
- Electropneumatic positioner etc.

#### Available options - on request only:

- Actuator - "cleaned and degreased for oxygen service"
- Electric actuator



#### Applications:

Approved for air gases, vapours and cryogenic liquefied gases incl. LNG.  
 Working temperature: -196°C / -321°F (77K) up to +120°C / +248°F (393K)

Materials	DIN EN	ASTM
1 Body	1.4308	A 351 CF8
1a Flange	1.4301	A 276 Grade 304
2 Valve seal	PTFE	
3 Disc	1.4301	A 276 Grade 304
4 Bonnet gasket	PTFE	
5 Headpiece	1.4301	A 276 Grade 304
6 Bolts	1.4301/A2	A 194 B8
7 Elongation tube	1.4541	A 213 TP 321
8 Stem	1.4301	A 276 Grade 304
9 Gland packing	Graphite / PTFE / MICA	
10 Gland nut	1.4305	A 276 Grade 303
11 Pillars	1.4571	A 313 Grade 316TI
12 Bush	CW452K	B 159 UNS C51900

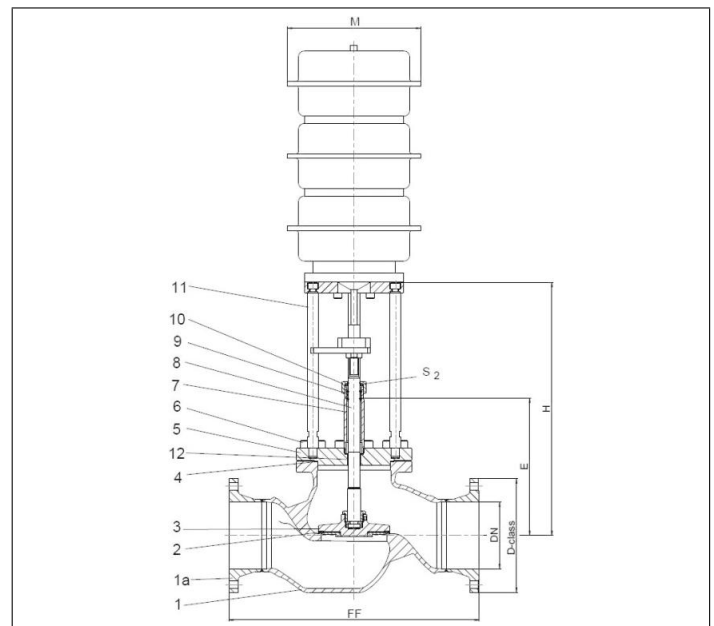

Type 03343 - Standard design	Technical data	
Nominal size	DN	200
Dimension code	.X.	8000
Flange-Ø	D-class	345
Face-to-face dimension	FF	760
Height	H	785
Length	E	410
Actuator-Ø	M	dependent on actuator
Wrench size across flats	S <sub>2</sub>	30
Weight w/o actuator	ca. kg	135
*Kvs-Value	m <sup>3</sup> /h	680
*Cv-Value	gal/min	793
Stroke	mm	60

Dimensions in mm. \* These figures refer to measurements for the flow direction.