

Check Valves

Type 05418 - Check Valve, DIN EN Flanges



Cryogenic-Check Valves, PN40

Stainless steel body and bronze cap
with spring, opening pressure ca. 0.1 bar
"cleaned and degreased for oxygen service"

Part No. 05418.X.0002

Flanged connection acc. to DIN EN 1092-1 PN40

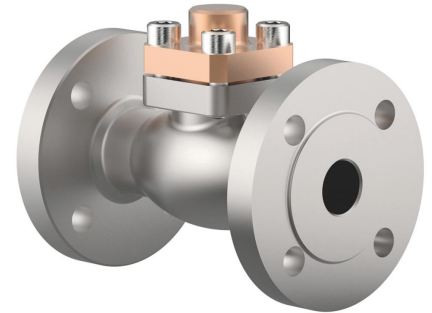

Applications:

Approved for air gases, vapours and cryogenic liquefied gases incl. LNG.
Working temperature: -196°C / -321°F (77K) up to +120°C / +248°F (393K)

Materials	DIN EN	ASTM
1 Body	1.4308	A 351 CF8
2 Valve seal up to DN50	PTFE / Carbon filled (25%)	
2a Valve seal from DN65	PTFE	
3 Disc	CW614N	B 283 UNS C38500
4 Spring	CW452K	B 159 UNS C51900
5 Bonnet gasket	PTFE	
6 Bolts	1.4301/A2	A 194 B8
7 Cap	CC493K	B 505 UNS C93200

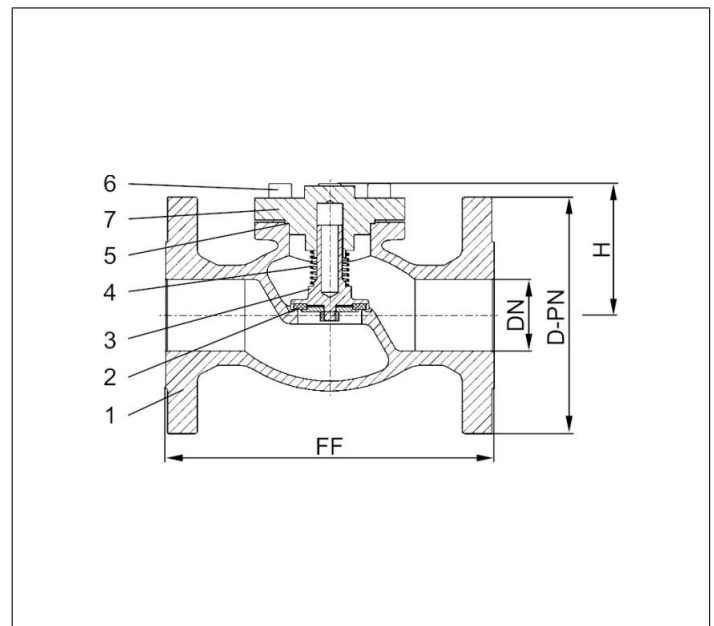

Type 05418 - Standard design	Technical data									
Nominal size	DN	15	20	25	40	50	65	80	100	150
Dimension code - Flange EN 1092-1 PN40	.X.	0150	0200	0250	0400	0500	0650	0800	1000	1500
Flange-Ø	D-PN	95	105	115	150	165	185	200	235	300
Face-to-face dimension	FF	140	150	160	200	230	290	310	350	550
Height	H	70	75	75	95	90	125	150	165	215
Weight	ca. kg	2.9	3.4	4.4	6.4	11.6	19.2	25.2	39.8	72.7
Kvs-Value	m ³ /h	4.3	6.7	11.5	22.6	37.1	71.1	104.0	170.0	350.0
Cv-Value	gal/min	5.0	7.8	13.4	26.3	43.2	82.9	121.3	198.3	408.4

Dimensions in mm. Leakage rates will be provided on request