

Check Valves

Type 05418 - Check Valve, ASME B16.5 Flanges



Cryogenic-Check Valves, class 300

Stainless steel body and bronze cap
with spring, opening pressure ca. 0.1 bar
"cleaned and degreased for oxygen service"

Part No. 05418.X.0003

Flanged connection acc. to ASME B16.5 class 300

Check valves provide reliable backflow functionality when properly sized. Based on experience, the minimum operating range of the valve should be 50% for gases and 40% for liquids in relation to the total capacity of the valve. Lower flow rates can lead to unstable performance, excessive noise, and even component failure.

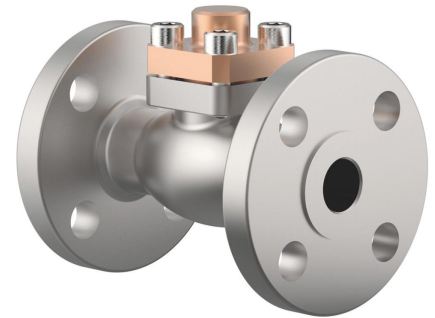

Applications:

Approved for air gases, vapours and cryogenic liquefied gases incl. LNG.
Working temperature: -196°C / -321°F (77K) up to +120°C / +248°F (393K)

Materials	DIN EN	ASTM
1 Body	1.4308	A 351 CF8
2 Valve seal up to DN50	PTFE / Carbon filled (25%)	
2a Valve seal from DN65	PTFE	
3 Disc	CW614N	B 283 UNS C38500
4 Spring	CW452K	B 159 UNS C51900
5 Bonnet gasket	PTFE	
6 Bolts	1.4301/A2	A 194 B8
7 Cap	CC493K	B 505 UNS C93200

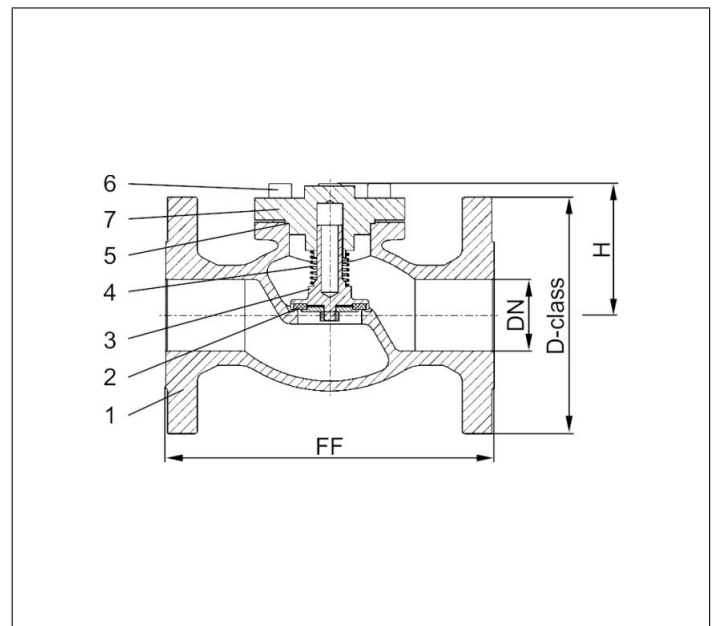

Type 05418 - Standard design	Technical data									
Nominal size	DN	15	20	25	40	50	65	80	100	150
Dimension code - Flange ASME B16.5 class 300	.X.	0400	0600	1000	1400	2000	2400	3000	4000	6000
Flange-Ø	D-class	95	115	125	155	165	190	210	255	320
Face-to-face dimension	FF	140	150	160	200	230	290	310	350	597
Height	H	70	75	75	95	90	125	150	165	215
Weight	ca. kg	2.9	3.4	4.4	6.4	11.6	19.2	25.2	39.8	90.3
Kvs-Value	m ³ /h	4.3	6.7	11.5	22.6	37.1	71.1	104.0	170.0	350.0
Cv-Value	gal/min	5.0	7.8	13.4	26.3	43.2	82.9	121.3	198.3	408.4

Dimensions in mm. Leakage rates will be provided on request