

Fire Safe Valves

Type 05614 - Check Valve



"Fire Safe"-design without fire type-testing according to EN ISO 10497

Cryogenic-Check Valves, PN50 (DN150=PN40)

Stainless steel body and cap

with spring, opening pressure ca. 0.1 bar

"cleaned and degreased for oxygen service"

Part No. 05614.X.000*

Butt or Socket weld connection for stainless steel pipes acc. to ISO 1127 or ASTM A312

Disc seal: PTFE / Carbon filled (25%)

Available options - on request only:

· Welded stainless steel stubs acc. to ISO 1127 or ASTM A312 - length FF + 200mm



Check valves provide reliable backflow functionality when properly sized. Based on experience, the minimum operating range of the valve should be 50% for gases and 40% for liquids in relation to the total capacity of the valve. Lower flow rates can lead to unstable performance, excessive noise, and even component failure.

Applications:

Approved for air gases, vapours and cryogenic liquefied gases incl. LNG.

Working temperature: -196°C / -321°F (77K) up to +120°C / +248°F (393K)

Materials	DIN EN	ASTM
1 Body	1.4308	A 351 CF8
2 Valve seal	PTFE / Carbon filled (25%)	
3 Disc	1.4301	A 276 Grade 304
4 Spring	1.4571	A 313 Grade 316Ti
5 Bonnet gasket	Graphite	
6 Bolts	1.4301/A2	A 194 B8
7 Cap	1.4301	A 276 Grade 304
7a Bush from DN65	PTFE	

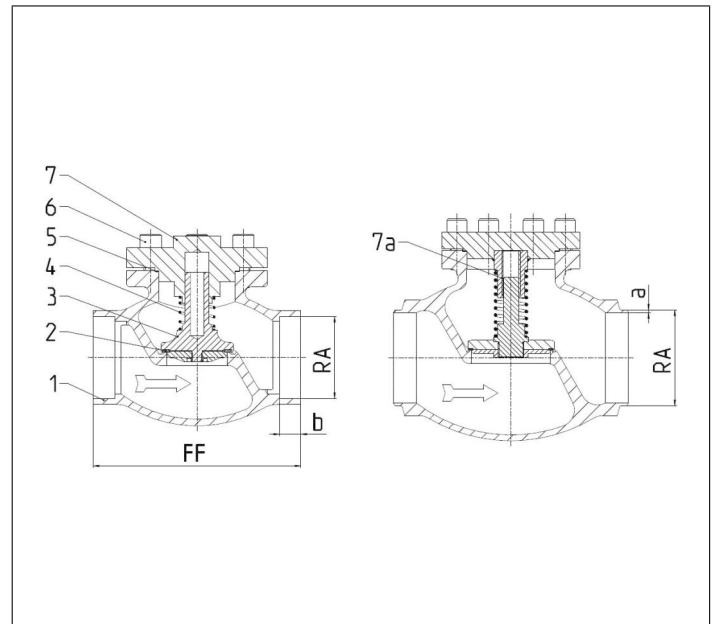

Type 05614 - Standard design	Technical data														
	DN	10	15	15	20	25	32	40	40	50	65	80	100	150	
Nominal size	DN	10	15	15	20	25	32	40	40	50	65	80	100	150	
Dimension code	.X.	1012	1517	1521	2026	2533	3238	4042	4048	5060	657x	8088	0114	0168	
Face-to-face dimension	FF	70	85	85	100	115	115	130	130	155	205	245	280	400	
Height	H	71	71	71	72	75	87	95	95	95	125	150	185	214	
Outside pipe-Ø ISO 1127	RA	12.0	17.2	21.3	26.9	33.7	38.0	42.4	48.3	60.3	76.1	88.9	114.3	168.3	
Wall thickness pipe ISO 1127	a	1.0	1.6	2.0	2.0	2.0	2.0	2.0	2.0	2.0	2.9	3.2	6.0	7.1	
Outside pipe-Ø ASTM A312	RA	13.72	17.15	21.34	26.67	33.40	-	42.16	48.26	60.33	73.03	88.90	114.30	168.30	
Wall thickness pipe ASTM A312	a	dimensions acc. to S10 or S40													
Socket depth	b	6	10	10	13	13	-	13	13	16	16	16	20	20	
Weight	ca. kg	0.7	0.95	1.0	1.3	1.6	2.4	3.9	3.9	5.7	9.6	14.6	20.0	50.0	
Kvs-Value	m ³ /h	1.6	3.8	4.3	6.7	11.5	14.0	20.6	22.6	37.1	71.1	104.0	170.0	350.0	
Cv-Value	gal/mir	1.9	4.4	5.0	7.8	13.4	16.2	23.9	26.3	43.2	82.9	121.3	198.3	408.4	

Dimensions in mm. Leakage rates will be provided on request