

Safety Valves

Type 06421



Cryogenic Safety Valves, angle type, bronze, PN40
 $d_0=7,0$ & $10,5$ mm up to PN50,
 type tested TÜV-SV.1111. S/G

Standard safety valve,
 with PCTFE valve seal (except $d_0=7$, which is metal to metal seated only: in this case
 the **Part No.** changes from **06421.X.X000** to **06421.070X.X100**), closed bonnet
 "cleaned and degreased for oxygen service"

Part No. 06421.X.0000

Inlet: female thread type G (BSPP) acc. to ISO 228/1
 Outlet: female thread type G (BSPP) acc. to ISO 228/1

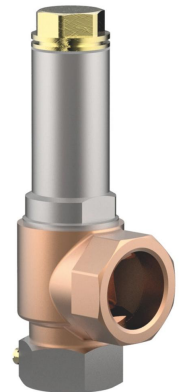

Applications:

Provided as safety device for protection against excessive pressure in stationary and moveable gas cylinders and pressure vessels. Approved for air gases, vapours and cryogenic liquefied gases incl. LNG.
 Working temperature: -196°C / -321°F (77K) up to $+185^{\circ}\text{C}$ / $+365^{\circ}\text{F}$ (458K), with PCTFE-seal up to $+150^{\circ}\text{C}$ / 302°F (423K), suitable for horizontal installation

Materials	DIN EN	ASME/ASTM
1 Outlet body	CC491K	SB 62 UNS C83600
2 Inlet body	1.4301	SA 479 Grade 304
3 Valve seal	PCTFE 1.4571 1.4541	A 313 Grade 316Ti ($d_0=7$) A 276 Grade 321 ($d_0=10.5$)
4 Disc	CC493K	B 505 UNS C93200
5 Guide plate	CW493K	B 505 UNS C93200
6 Stem	CW453K	B 103 UNS C52100
7 Spring	1.4571	A 313 Grade 316Ti
8 Bonnet	1.4301	A 276 Grade 304
9 Spring clamp	CW614N	B 455 UNS C38500
10 Thread ring	CW614N	B 455 UNS C38500
11 Cap	CW614N	B 455 UNS C38500

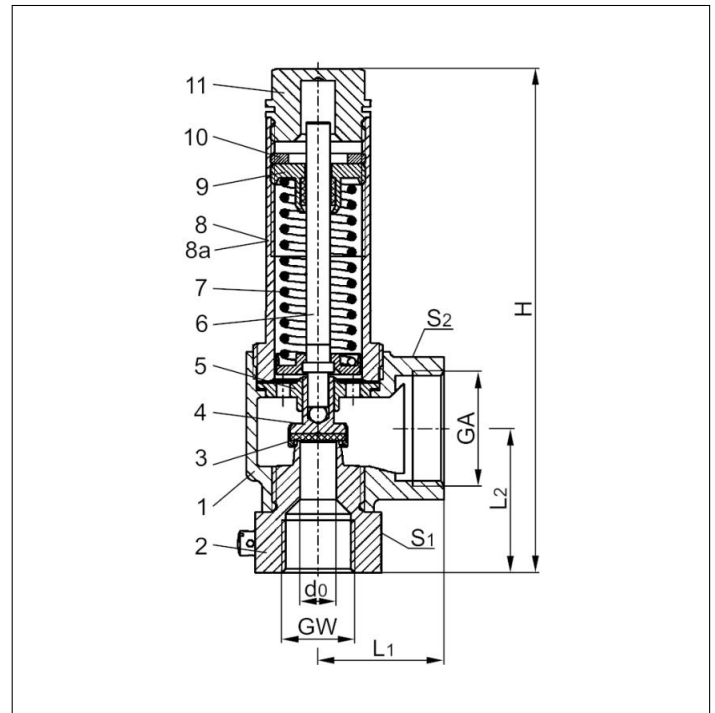

Type 06421	Technical data					
Nominal size	GW	1/2	1/2	3/4	1	1-1/4
Orifice	d_0	7.0	10.5	14.0	18.0	23.0
Dimension Code	.X.	0704	1004	1406	1810	2312
Set pressure range	bar	0.4-50.0	0.4-50.0	0.4-40.0	0.4-40.0	0.4-10.0
Outlet	GA	1	1	1-1/4	1-1/2	1-1/2
Height	H	145	145	164	195	200
Length	L_1	36	36	50	48	48
Length	L_2	41.5	41.5	49	59.5	65
Wrench size across flats	S_1	36	36	41	50	50
Wrench size across flats	S_2	41	41	50	58	58
Weight	ca. kg	0.80	0.795	1.25	1.87	1.79
Coeff. of discharge from 3.0 bar	α_w	0.78	0.69	0.66	0.66	0.54

Dimensions in mm.

Safety Valves

Type 06421



Discharge capacities

Medium:

Air in m³/h at 0°C and 1013.25 mbar

Air in SCFM at 60°F (15.6°C) and 14.7 psia (1013.25 mbar)

The capacity indicated below is for a fully opened valve.

d₀ - orifice

A₀ - flow area

Calculation of discharge capacity acc. to AD2000-Merkblatt A2 / DIN EN ISO 4126-1 resp. ASME Code Sec. VIII.

Set pressure in bar (g)	GW	1/2	1/2	3/4	1	1-1/4
	d ₀ (mm)	7.0	10.5	14.0	18.0	23.0
	A ₀ (mm ²)	38.48	86.59	153.94	254.47	415.48
Medium		Air in m ³ /h				
0.4		24	43	77	123	157
0.5		27	49	87	141	179
1.0		41	77	131	216	287
1.5		54	101	179	291	376
2.0		66	126	219	362	473
3.0		88	176	299	495	661
4.0		111	221	375	621	829
5.0		134	266	453	748	1000
6.0		156	311	529	875	1169
7.0		179	356	606	1001	1337
8.0		202	402	684	1131	1511
9.0		225	447	761	1258	1680
10.0		248	494	839	1387	1853
12.0		293	584	993	1641	-
14.0		339	674	1147	1895	-
16.0		384	765	1300	2149	-
18.0		430	855	1454	2403	-
20.0		480	954	1623	2683	-
22.0		525	1046	1778	2939	-
24.0		571	1137	1933	3196	-
26.0		617	1228	2088	3452	-
28.0		663	1319	2244	3709	-
30.0		715	1424	2421	4003	-
32.0		762	1516	2578	4262	-
34.0		808	1608	2735	4520	-
36.0		854	1700	2891	4779	-
38.0		900	1792	3048	5038	-
40.0		955	1901	3232	5343	-
42.0		1002	1994	-	-	-
44.0		1048	2086	-	-	-
46.0		1095	2179	-	-	-
48.0		1142	2272	-	-	-
50.0		1198	2385	-	-	-

Set pressure in psig	GW	1/2	1/2	3/4	1	1-1/4
	d ₀ (inch)	0.276	0.413	0.551	0.709	0.906
	A ₀ (in ²)	0.060	0.134	0.239	0.394	0.644
Medium		Air in SCFM				
15		-	-	92	-	-
28		-	-	129	-	298
29		42	-	-	-	304
35		47	90	154	-	346
40		52	100	169	280	382
50		62	118	201	333	454
60		72	137	233	385	525
70		82	156	265	438	597
80		92	174	296	490	669
90		101	193	328	543	740
100		111	212	360	595	812
120		131	249	424	700	955
145		155	296	503	831	1134
160		170	324	551	910	-
180		190	361	614	1015	-
220		229	436	741	1225	-
240		249	473	805	1330	-
250		258	492	836	1383	-
260		268	511	868	1435	-
280		288	548	932	1540	-
300		307	585	995	1645	-
325		332	632	1075	1777	-
350		357	679	1154	1908	-
375		381	725	1233	2039	-
400		406	772	1313	2170	-
425		430	819	1392	2302	-
450		455	865	1472	2433	-
475		479	912	1551	2564	-
500		504	959	1630	2695	-
525		528	1006	1710	2827	-
550		553	1052	1789	2958	-
575		577	1099	1868	3089	-
600		602	1146	-	-	-
625		626	1192	-	-	-
650		651	1239	-	-	-
675		675	1286	-	-	-
700		700	1332	-	-	-
725		724	1379	-	-	-