

Strainers

Type 08412 - Strainer



Cryogenic-Strainer, PN50

Bronze body and cap
with strainer screen mesh size 0.25 mm
"cleaned and degreased for oxygen service"

Part No. 08412.X.0001

Socket end for copper pipes acc. to DIN EN 12449 or ASTM B88

Available options - on request only:

- Socket end for stainless steel pipes acc. to ISO 1127
- other mesh sizes for strainer screen (changed flow coefficient)
- strainer screen in bronze or monel
- sintered filter in bronze or stainless steel in various porosities

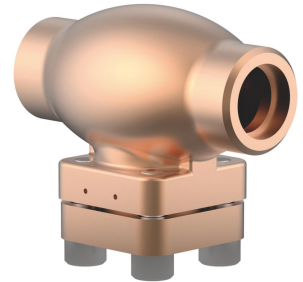

Applications:

Approved for air gases, vapours and cryogenic liquefied gases incl. LNG.
Working temperature: -196°C / -321°F (77K) up to +120°C / +248°F (393K)

Materials	DIN EN	ASTM
1 Body	CC491K	B 62 UNS C83600
2 Strainer screen	1.4301	A 240 Grade 304
3 Bonnet gasket	PTFE	
4 Bolts	1.4301/A2	A 194 B8
5 Cap	CC493K	B 505 UNS C93200

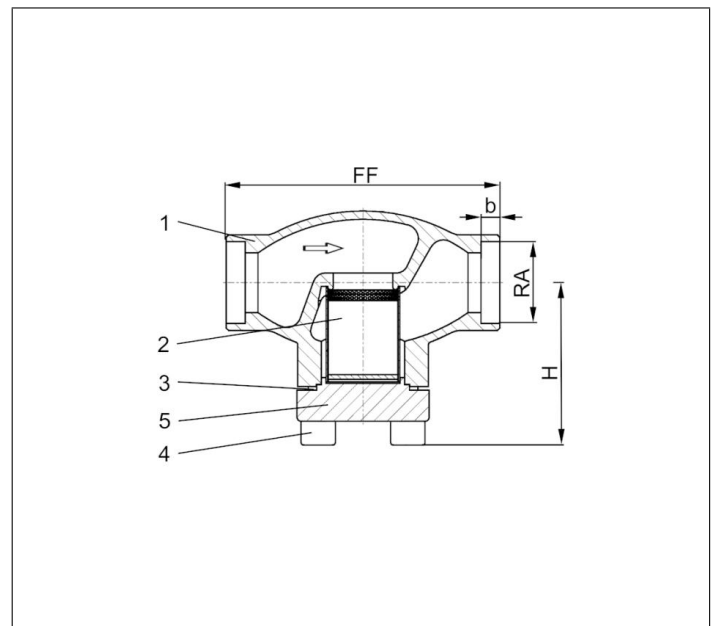

Type 08412 - Standard design	Technical data							
Nominal size	DN	10	15	20	25	32	40	50
Dimension code	.X.	X=DNRA, Example: valve DN10 for copper pipe RAø12mm, X=1012						
Face-to-face dimension	FF	60	85	85	115	115	140	160
Height	H	62	62	65	69	76	89	89
Outside pipe-Ø	RA	dependent on order						
Socket depth	b	6	6	8	8	10	13	20
Weight	ca. kg	0.6	0.8	0.9	1.2	1.8	3.1	4.7
Kvs-Value	m ³ /h	1.5	3.4	6.5	9.5	14.0	21.0	28.0
Cv-Value	gal/min	1.7	3.9	7.5	11.0	16.2	24.3	32.4

Dimensions in mm.