

Strainers

Type 08416 - Strainer



Cryogenic-Strainer, PN50

Stainless steel body and cap
with strainer screen mesh size 0.25 mm
"cleaned and degreased for oxygen service"

Part No. 08416.X.0001

Female thread connection (G) acc. to ISO 228/1

Part No. 08416.X.0006

Female thread connection NPT acc. to ANSI B 1.20.1

Available options - on request only:

- Female thread connection (R) acc. to ISO 7-Rc
- other mesh sizes for strainer screen (changed flow coefficient)
- strainer screen in bronze or monel
- sintered filter in bronze or stainless steel in various porosities



Applications:

Approved for air gases, vapours and cryogenic liquefied gases incl. LNG.
Working temperature: -196°C / -321°F (77K) up to +120°C / +248°F (393K)

Materials	DIN EN	ASTM
1 Body	1.4308	A 351 CF8
2 Strainer screen	1.4301	A 240 Grade 304
3 Bonnet gasket	PTFE	
4 Bolts	1.4301/A2	A 194 B8
5 Cap	1.4301	A 276 Grade 304

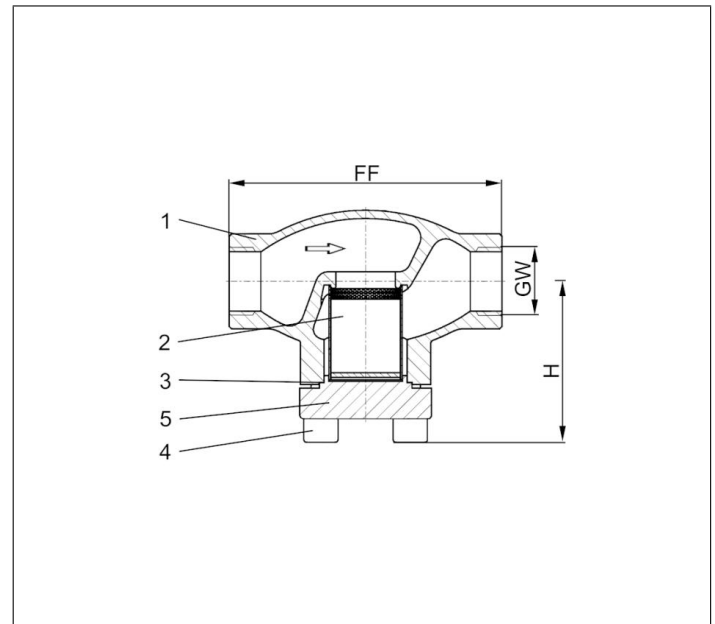

Type 08416 - Standard design	Technical data								
Nominal size	DN	10	10	15	20	25	40	40	50
Thread size	GW	1/4	3/8	1/2	3/4	1	1-1/4	1-1/2	2
Dimension code	.X.	0200	0300	0400	0600	1000	1200	1400	2000
Face-to-face dimension	FF	70	70	85	100	115	130	130	155
Height	H	62	62	62	65	69	89	89	89
Weight	ca. kg	0.6	0.6	0.8	0.9	1.2	3.1	3.1	4.7
Kvs-Value	m ³ /h	1.5	1.5	3.4	6.5	9.5	19.0	21.0	28.0
Cv-Value	gal/min	1.7	1.7	3.9	7.5	11.0	22.0	24.3	32.4

Dimensions in mm.