

Strainers

Type 08417 - Strainer



Cryogenic-Strainer, PN25

Stainless steel body and cap
with strainer screen mesh size 0.25 mm

Part No. 08417.0219.0004

Socket weld connection for stainless steel pipes acc. to ISO 1127 or ASTM A312

Available options - on request only



Applications:

Approved for air gases, vapours and cryogenic liquefied gases incl. LNG.
Working temperature: -196°C / -321°F (77K) up to +120°C / +248°F (393K)

Materials	DIN EN	ASTM
1 Body	1.4308	A 351 CF8
2 Strainer screen	1.4301	A 240 Grade 304
3 Bonnet gasket	PTFE	
4 Bolts	1.4301/A2	A 194 B8
5 Cap	1.4404	A 276 Grade 316L

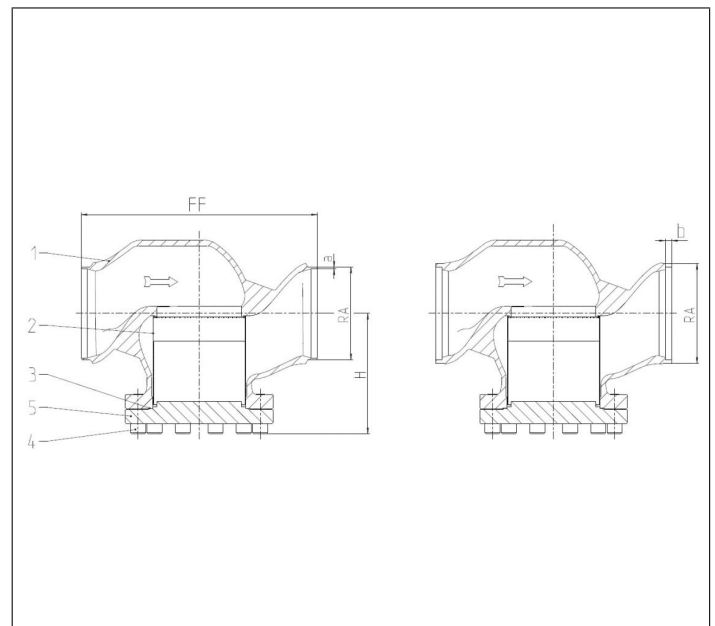

Type 08417 - Standard design	Technical data	
Nominal size	DN	200
Dimension code	.X.	0219
Face-to-face dimension	FF	560
Height	H	285
Outside pipe-Ø ISO 1127	RA	219.1
Wall thickness pipe ISO 1127	a	6.3
Outside pipe-Ø ASTM A312	RA	219.1
Wall thickness pipe ASTM A312	a	dimensions acc. to S10 or S40
Socket depth	b	15
Weight	ca. kg	100
Kvs-Value	m ³ /h	468
Cv-Value	gal/min	541.1

Dimensions in mm.