

Offshore Valves

Type 08732 - Strainer, DIN EN Flanges



Cryogenic-Strainer, PN40

Stainless steel body and cap
with strainer screen mesh size 0.25 mm
"cleaned and degreased for oxygen service"

Part No. 08732.X.0002

Flanged connection acc. to DIN EN 1092-1 PN40

Available options - on request only:

- other mesh sizes for strainer screen (changed flow coefficient)
- strainer screen in bronze or monel
- sintered filter in bronze or stainless steel in various porosities

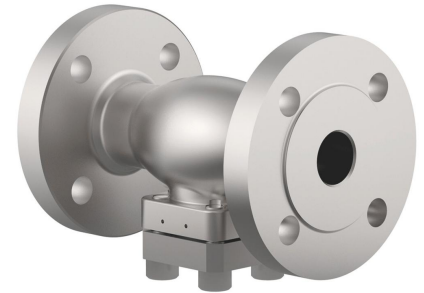

Applications:

Approved for air gases, vapours and cryogenic liquefied gases incl. LNG.
Working temperature: -255°C / -427°F (18K) up to +120°C / +248°F (393K)

Materials	DIN EN	ASTM
1 Body	1.4409	A 351 CF3M
2 Strainer screen	1.4404	A 276 Grade 316L
3 Bonnet gasket	Graphite	
4 Bolts	1.4571/A4 similar A 194 B8T	
5 Cap	1.4404	A 276 Grade 316L

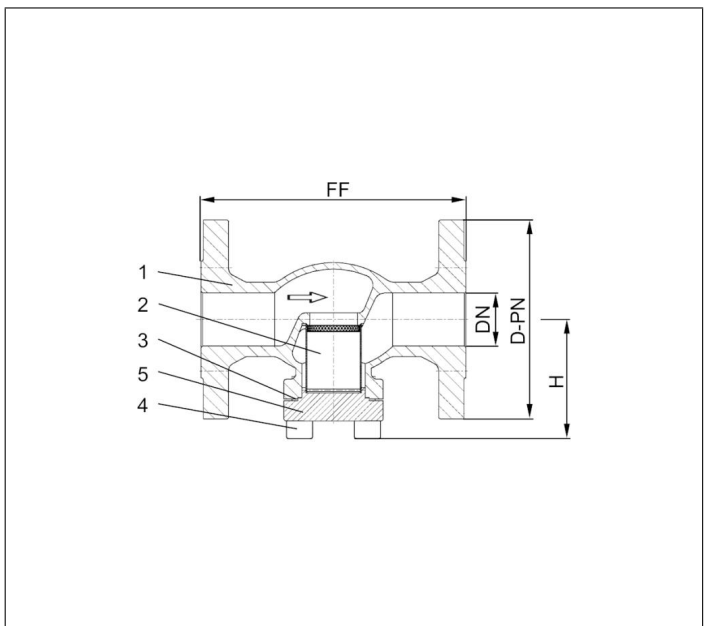

Type 08732 - Standard design	Technical data									
Nominal size	DN	15	20	25	40	50	65	80	100	150
Dimension code - Flange EN 1092-1 PN40	.X.	0150	0200	0250	0400	0500	0650	0800	1000	1500
Flange-Ø	D-PN	95	105	115	150	165	185	200	235	300
Face-to-face dimension	FF	140	150	160	200	230	290	310	350	550
Height	H	62	69	69	89	89	125	150	166	212
Weight	ca. kg	2.5	3.0	4.0	5.6	10.6	17.7	23.2	36.8	68.1
Kvs-Value	m ³ /h	4.3	6.7	9.5	21.0	28.0	62.0	90.0	118.0	on request
Cv-Value	gal/min	5.0	7.8	11.0	24.3	32.4	72.3	105.0	137.7	on request

Dimensions in mm.