

Actuated Valves and Actuators

Type 09443 - Actuated Gate Valve



Cryogenic-Gate Valves with Pneumatic Actuator, PN50

air pressure for operation 4.0 bar g (maximal 10.0 bar g),

Stainless steel body and topwork,

Actuator - air opens, spring closes

one way tightening (in flow direction),

"live loaded" gland packing

"cleaned and degreased for oxygen service" - the actuator is not cleaned and degreased for oxygen

Working pressure: 5 - 50 bar, Leakage rate A acc. to DIN EN 12266

Working pressure: 0.7 - 4.9 bar, Leakage rate B acc. to DIN EN 12266

Part No. 09443.X.T021

Male thread for union connection

Available options - on request only:

- Weather protection hood

Applications:

Approved for air gases, vapours and cryogenic liquefied gases incl. LNG.

Working temperature: -196°C / -321°F (77K) up to +120°C / +248°F (393K)

Ambient temperature actuator: -50°C / -58°F (223K) up to +70°C / +158°F (343K)



Materials	DIN EN	ASTM
1 Body	1.4308	A 351 CF8
2 Valve seal	PTFE / Carbon filled (25%)	
3 Disc	CW452K	B 159 UNS C51900
4 Wedge	1.4308	A 351 CF8
5 Stem	1.4301	A 276 Grade 304
6 Bonnet gasket	PTFE	
7 Headpiece	1.4301	A 276 Grade 304
8 Bolts	1.4301/A2	A 194 B8
9 Elongation tube	1.4541	A 213 TP 321
10 Spring	1.4571	A 313 Grade 316Ti
11 Flange	1.4301	A 276 Grade 304
12 Headpiece	1.4301	A 276 Grade 304
13 Gland packing	Graphite / PTFE / MICA	
14 Gland nut	1.4305	A 276 Grade 303
15 Pillars	1.4301	A 276 Grade 304
16 Bush	CW452K	B 159 UNS C51900
17 Actuator	Rubberchuk	

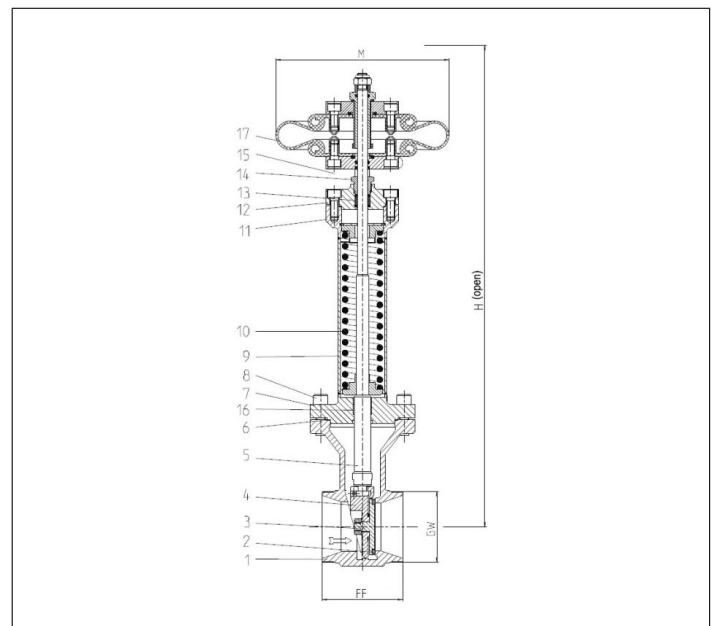

Type 09443 - Standard design	Technical data				
Nominal size	DN	25	40	50	65
Dimension code	.X.	0250	0400	0500	0650
Thread (G- / M-thread)	GW	- / M40x2	G2 / M65x2	G2-1/2 / M78x2	G3 / M88x2
Face-to-face dimension	FF	133	133	110	110
Height	H	500	560	590	630
Actuator-Ø	M	229	229	229	229
Weight	ca. kg	9.9	11.1	13.5	14.9
*Kvs-Value	m ³ /h	43	93	125	227
*Cv-Value	gal/min	51	111	149	264

Dimensions in mm. * These figures refer to measurements for the flow direction.