

Spare Parts for Valves and Fill Cluster

Type 11C01 - Globe Valve FullX



Top-Entry Cryogenic-Globe Valves - Bellow in top position

"cleaned and degreased for oxygen service"

Part No. 11C01.X.E00301 - manual



suitable for:

Type	Nominal size
11C01.001X.E00301	DN10 - DN15
11C01.002X.E00301	DN20 - DN25
11C01.3240.E00301	DN32 - DN40
11C01.0050.E00301	DN50

Materials	DIN EN	ASTM
1 Valve seal	PCTFE	
2 Disc	1.4571	A 313 Grade 316Ti
3 Bushing	PTFE / Electrocarbon (25%)	
4 Hollow stem	1.4571	A 313 Grade TP316Ti
5 Bonnet gasket	PTFE	
6 Bolts	A4-70	A 194 B8M
7 Stem	1.4404	A 276 Grade 316L
8 Headpiece	1.4404	A 276 Grade 316L
9 Valve Seal	PTFE / Electrocarbon (25%)	
10 Gland bold	1.4404	A 276 Grade 316L
11 Handwheel	1.4409	CF3M

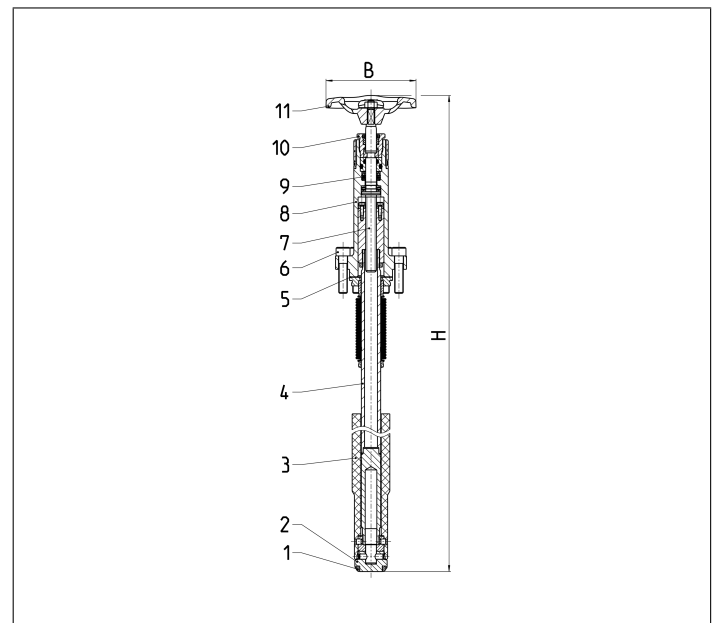

Type 11C01	Technical data							
Nominal size	DN	10	15	20	25	32	40	50
Dimension code	.X.	001X	001X	002X	002X	3240	3240	0050
Height	H	529	529	529	529	677	677	762
Handwheel-Ø	B	100	100	100	100	125	125	125
Weight	ca. kg	2.1	2.1	2.3	2.3	5.1	5.1	10.3

Dimensions in mm.