

Ball Valves and Spare Parts

Type 15C01 - Ball Valve full bore



Cryogenic Ball Valve

Unidirectional ball valve to be installed in flow direction with upstream pressure relief hole.
 Socket weld connection for stainless steel pipes acc. to ISO 1127 or ASTM A312
 Butt weld connection for stainless steel pipes acc. to ISO 1127 or ASTM A312
 Female thread type NPT acc. to ANSI 1.20.1
 Female thread type G (BSPP) acc. to ISO 228/1
 Marking acc. to EN 1626
 Top flange to EN ISO 5211
 "cleaned and degreased for oxygen service"

Available accessories:

- Lock for locking device type 55394.0019.0302



Applications:

Approved for air gases, vapours and cryogenic liquefied gases incl. LNG.
 Working temperature: -196°C / -321°F (77K) up to +65°C / +149°F (338K)

Materials	DIN EN	ASTM
1 Body	1.4409	A 351 CF3M
2 Ball seal	PCTFE	
3 Ball	1.4404	316L S.S.
4 Side connection	1.4409	A 351 CF3M
5 Stem	1.4401	A 479 Grade 316
6 Bonnet extension	1.4409	A 351 CF3M
7 Gland packing	INOFLON M295	
8 Lever	1.4301	ASTM A312 TP304

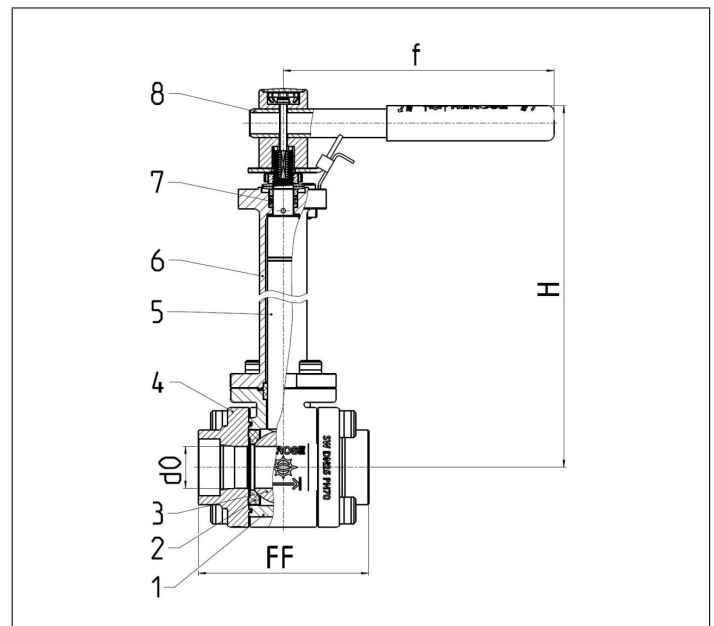

Technical data - Standard design							
Nominal size [DN]	Height (H) [mm]	Orifice (D ₀) [mm]	Weight [kg]	Kvs-value [m ³ /h]	Cv-value [gal/min]	Length (f) [mm]	ISO 5211
10	296	8.0	2.5	5.7	6.6	127	F03
15	296	14.5	2.5	10.7	12.4	127	F03
20	305	19.5	3.1	24.7	28.6	157	F04
25	310	25.0	3.8	32.1	37.1	157	F04
32	376	32.0	6.5	77.9	90.1	240	F05
40	380	38.0	7.3	122.3	141.4	240	F05
50	427	50.0	13.6	124.1	143.7	420	F07
65	496	64.5	29.8	188.6	218.4	462.5	F10
80	592	80.0	44.7	279.8	323.7	600	F10

Ball Valves and Spare Parts

Type 15C01 - Ball Valve full bore



Connection types

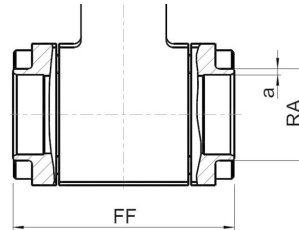

Butt weld connection acc. to · ISO 1127

DN	Nominal Pressure [PN]	Face-to-face dim. (FF) [mm]	Outside pipe-Ø ISO (RA) [mm]	Wall thickness pipe ISO (a) [mm]	Part No.
10	100	65	13.5	2.0	15C01.A001.000201
15	100	70	21.3	2.0	15C01.A001.000207
20	100	85	26.3	2.0	15C01.A001.000213
25	70	100	33.7	2.6	15C01.A001.000219
32	70	115	42.4	2.6	15C01.A001.000225
40	70	125	48.3	3.2	15C01.A001.000231
50	70	160	60.3	3.2	15C01.A001.000237
65	30	182.5	76.1	2.9	15C01.A001.000243
80	20	218	88.9	3.2	15C01.A001.000247

Butt weld connection acc. to · ASTM A312

DN	Nominal Pressure [PN]	Face-to-face dim. (FF) [mm]	Outside pipe-Ø ASTM (RA) [mm]	Wall thickness pipe ASTM (a) [mm]	Part No.
10	100	65	13.72	1.65	15C01.A001.000204
10	100	65	13.72	2.24	15C01.A001.000205
15	100	70	21.35	2.11	15C01.A001.000210
15	100	70	21.35	2.78	15C01.A001.000211
20	100	85	26.70	2.10	15C01.A001.000216
20	100	85	26.70	2.85	15C01.A001.000217
25	70	100	33.40	2.77	15C01.A001.000222
25	70	100	33.40	3.38	15C01.A001.000223
32	70	115	42.20	2.77	15C01.A001.000228
32	70	115	42.20	3.56	15C01.A001.000229
40	70	125	48.30	2.77	15C01.A001.000234
40	70	125	48.30	3.70	15C01.A001.000235
50	70	160	60.33	2.77	15C01.A001.000240
50	70	160	60.33	3.91	15C01.A001.000241
65	30	182.5	73.10	3.10	15C01.A001.000244
65	30	182.5	73.10	5.20	15C01.A001.000245
80	20	218	88.90	3.10	15C01.A001.000248
80	20	218	88.90	5.45	15C01.A001.000249

Ball Valves and Spare Parts

Type 15C01 - Ball Valve full bore

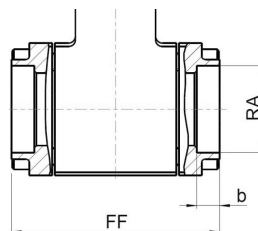

Socket weld connection acc. to

- ISO 1127
- ASTM A312

DN	Nominal Pressure [PN]	Face-to-face dim. (FF) [mm]	Socket depth (b) [mm]	Socket diameter (RA) [mm]	Part No.
10	100	65	6.0	14.1	15C01.A001.000200
15	100	70	10.0	22.0	15C01.A001.000206
20	100	85	13.0	27.5	15C01.A001.000212
25	70	100	13.0	34.0	15C01.A001.000218
32	70	115	13.0	38.2	15C01.A001.000224
40	70	125	13.0	48.7	15C01.A001.000230
50	70	160	16.0	60.3	15C01.A001.000236
65	10	182.5	16.0	77.0	15C01.A001.000242
80	10	218	16.0	90.0	15C01.A001.000246

Female thread type

- NPT acc. to ANSI 1.20.1
- G (BSPP) acc. to ISO 228/1

DN	Nominal Pressure [PN]	Face-to-face dim. (FF) [mm]	Thread size (GW) [mm]	Part No.
10	100	65	G 3/8	15C01.A001.000202
10	100	65	NPT 3/8	15C01.A001.000203
15	100	70	G 1/2	15C01.A001.000208
15	100	70	NPT 1/2	15C01.A001.000209
20	100	85	G 3/4	15C01.A001.000214
20	100	85	NPT 3/4	15C01.A001.000215
25	70	100	G 1	15C01.A001.000220
25	70	100	NPT 1	15C01.A001.000221
32	70	115	G 1 1/4	15C01.A001.000226
32	70	115	NPT 1 1/4	15C01.A001.000227
40	70	125	G 1 1/2	15C01.A001.000232
40	70	125	NPT 1 1/2	15C01.A001.000233
50	70	160	G 2	15C01.A001.000238
50	70	160	NPT 2	15C01.A001.000239