

Actuated Valves and Actuators

Type 27515 - Pneumatic Actuator - Control Valve



Pneumatic Actuators for Control Valves

Actuator - **spring to open**, air to close

maximum air pressure for operation 6.0 bar

Actuator coating: Delta Seal GZ (silver-grey)

Corrosion-protection class C5-M acc. to DIN EN ISO 12944

Available options - on request only:

- Pneumatic actuator with override handwheel

Ambient temperature limit: -40°C / -40°F (233K) up to +100°C / 212°F (373K)



Overview - required actuator sizes for differential pressures

DN	Differential pressure in bar		
	1.0	21.1	45.1
	-	-	-
	21.0	45.0	50.0
10	A	A	A
15	A	A	A
20	A	A	A
25	A	A	B
32	B	B	B
40	B	B	B
50	B	B	B
65	D	D	D
80	D	D	D
100	D	D	o.r.
150	D	o.r. - on request	

The differential pressures are based on the flow direction of the valve.

Differential pressures against the flow direction have to be requested separately.

Code in Table	Part No. Actuator
A	27515.DP30.2S06
B	27515.DP32.3S02
C	27515.DP33.3S02
D	27515.DP34.5S02

Materials	DIN EN	ASTM
1 Body	1.0335	A 622 Grade 1008
2 Diaphragm	NBR + tissue	
3 Springs	1.4310	A 313 Grade 301
4 Actuator stem	1.4571	A 276 Grade 316Ti
5 Coupling	1.4571	A 276 Grade 316Ti

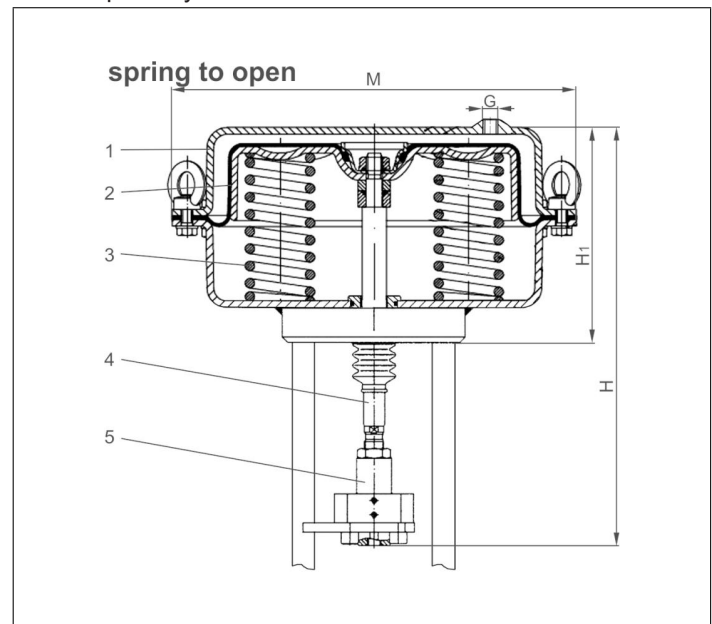

Type 27515		Technical data			
Part No. Actuator	27515				
	.DP30.2S06	.DP32.3S02	.DP33.3S02	.DP34.5S02	
Diameter Actuator	M	168	250	300	405
Height	H	ca. 244	ca. 240	ca. 300	ca. 375
Height	H1	122	124	166	228
Thread	G	G 1/4"	G 1/4"	G 1/4"	G 3/8"
Diaphragm area	cm ²	80	250	400	800
Spring range	bar	0.6 - 1.5	0.2 - 1.0	0.2 - 1.0	0.2 - 1.0
Minimum air pressure	bar	6.0	6.0	6.0	6.0
Regulating lift	mm	20	30	30	50
Weight	ca. kg	5.0	9.0	15.0	45.0

Dimensions in mm.