



Pneumatic Actuators for Globe Valves (on/off)

Actuator - air to open, **spring to close**

Air supply - maximum 6.0 bar g

Body - stainless steel (1.4571) electropolished

"cleaned and degreased for oxygen service"

Ambient temperature limit: -40°C / -40°F (233K) up to +80°C / 176°F (353K)

Overview - required actuator sizes for differential pressures

DN	Differential pressure in bar												
	1.0	3.1	4.1	7.1	10.1	11.1	15.1	18.1	20.1	22.1	30.1	33.1	35.1
	3.0	4.0	7.0	10.0	11.0	15.0	18.0	20.0	22.0	30.0	33.0	35.0	50.0
10	B	B	B	B	B	B	B	B	B	B	B	B	B
15	B	B	B	B	B	B	B	B	B	B	B	B	B
20	B	B	B	B	B	B	B	B	B	B	B	B	B
25	B	B	B	B	B	B	B	B	B	B	B	B	B
32	B	B	B	B	B	B	B	B	B	B	B	B	C
40	B	B	B	B	B	B	B	B	B	C	C	C	C
50	B	B	B	B	B	B	C	C	C	C	C	C	o.r.
65	B	B	B	C	C	C	C	o.r. - on request					
80	B	B	C	C	o.r. - on request								
100	B	o.r. - on request											
150	o.r. - on request												



The differential pressures are based on the flow direction of the valve.

Differential pressures against the flow direction have to be requested separately.

Code in Table	Part No.	Actuator
B	27521.35B6.6GPO	
C	27521.60A6.6GPO	

Materials	DIN EN	ASTM
1 Body	1.4571	A 240 Grade 316Ti
2 Body	1.4571	A 240 Grade 316Ti
3 Diaphragm	EPDM	
4 Springs	Cr.Si-Leg.*	
5 Actuator stem	1.4571	A 276 Grade 316Ti
6 Coupling	1.4571	A 240 Grade 316Ti
* Coating:	material is corrosion resistant (Microcor Spezial) corrosion protection class C5-M	

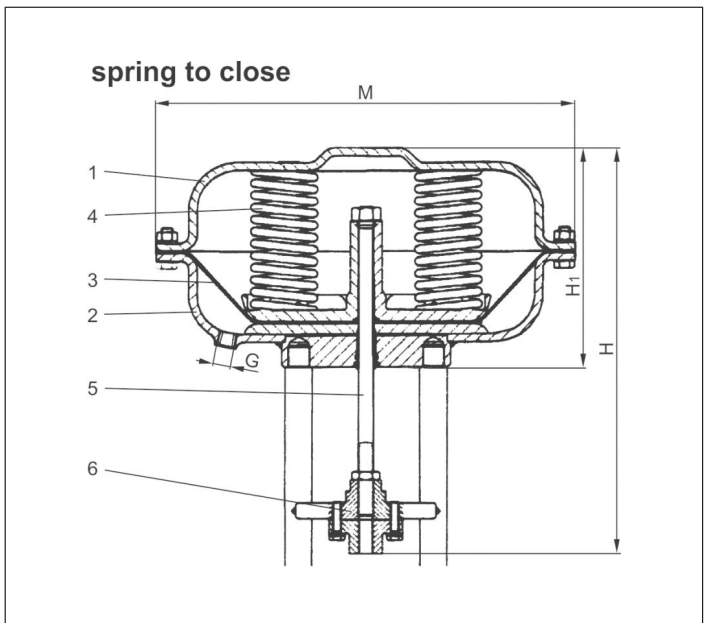

Type 27521	Technical data		
Part No. Actuator	27521		
	.35B6.6GPO	.60A6.6GPO	
Diameter Actuator	M	210	310
Height	H	276	309
Height	H1	136	166
Thread	G	1/4" NPT	1/4" NPT
Diaphragm area	cm ²	280	530
Spring rage	bar	0.8 - 3.0	0.8 - 2.8
Minimum air pressure	bar	3.2	3.0
Regulating lift	mm	35	40
Weight	ca. kg	5.0	12.5

Dimensions in mm.