

# Pressure Regulator

## Type T118 - Globe Valve



### Cryogenic Globe Valves with check unit, PN50

suitable for CombiPressure-Regulator type 4182/4186

Material: Stainless steel  
 Connections: Male thread for union connection  
 Installation position: Vertically

"cleaned and degreased for oxygen service"

#### Part No. T118.X.1A0C0

Male thread for union connection

Available options - on request only:

- Butt weld connection for stainless steel pipes acc. to ISO 1127 or ASTM A312
- Union type butt weld fittings for stainless steel pipes acc. to ISO 1127 or ASTM A312
- Union type braze fittings for copper pipes acc. to DIN EN 12449 or ASTM B88
- Thread connection NPT acc. to ANSI B 1.20.1

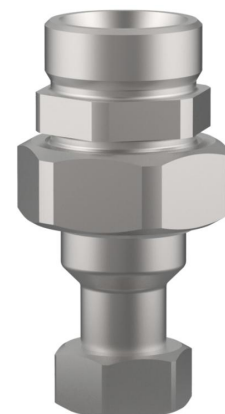

#### Applications:

Approved for air gases, vapours and cryogenic liquefied gases incl. LNG.

Working temperature: -196°C / -321°F (77K) up to +65°C / 149°F (338K)

Ambient temperature: -40°C / -40°F (233K) up to +65°C / 149°F (338K)

Maximum operating pressure: 50bar

Materials	DIN EN	ASTM
1 Body	1.4571	A 313 Grade 316Ti
2 Stem	1.4571	A 313 Grade 316Ti
3 Seal	PTFE	
4 Spring plate	1.4301	A 276 Grade 304
5 Gland nut	1.4301	A 276 Grade 304
6 O-ring	PTFE	
7 Spring	1.4571	A 313 Grade 316Ti
8 Snap ring	-	-
9 Guiding disc	1.4571	A 313 Grade 316Ti
10 Body	1.4571	A 313 Grade 316Ti
11 Ball	PTFE	
12 Snap ring	-	-
13 Gland nut	1.4301	A 276 Grade 304
14 Lock ring	1.4122	-
15 Spring compressor	1.4571	A 313 Grade 316Ti
16 Lock ring	1.4435	-

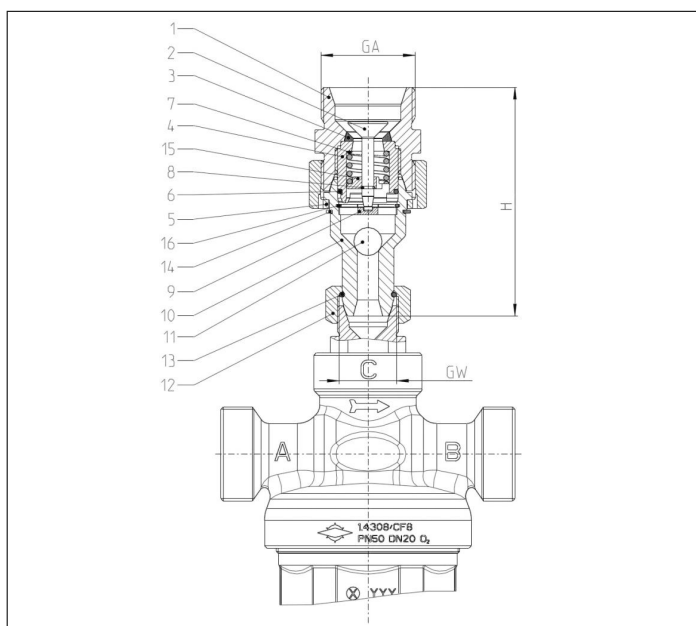

Type T118	Technical data	
Nominal size	DN	20
Dimension code	.X.	FM02615
Height	H	97
Thread	GA	M40x2.0
Thread	GW	M26x1.5
Weight	ca. kg	0.7
Kvs-Value	m <sup>3</sup> /h	2.0
Cv-Value	gal/min	2.3

Dimensions in mm.