

# Check Valves

## Type 05011, Type 05012



### Check Valves, PN16, DIN EN 3845-2

Bronze body, screwed cap in brass

#### Part No. 05011.X.0000

Female thread type G (BSPP) acc. to ISO 228/1  
Disc with FPM seal

#### Part No. 05012.X.0000

Female thread type G (BSPP) acc. to ISO 228/1  
Disc with PTFE seal

Available options - on request only:

- Disc with EPDM seal
- Disc with NBR seal



### Applications:

Suitable for non-toxic, non-inflammable fluids, gases and vapours.

The laws, regulations and standards are to observe for the range of application.

Working temperatures and pressures:

up to max. 16.0 bar: -10°C / +14°F (263K) up to +80°C / +176°F (353K)

up to max. 10.0 bar: -10°C / +14°F (263K) up to +120°C / +248°F (393K)

up to max. 6.0 bar: -10°C / +14°F (263K) up to +160°C / +320°F (433K)

Materials	DIN EN	ASTM
1 Body	CC491K	B 62 UNS C83600
2 Seal Type 05011	FPM	
2 Seal Type 05012	PTFE	
3 Disc	CW614N	B 283 UNS C38500
4 Spring	1.4310	A 313 Grade 301
5 Guide piece	CW614N	B 283 UNS C38500
6 Cap	CW614N	B 283 UNS C38500

**Essential:** When ordering or requesting an offer please indicate flow medium, working pressure and working temperature.

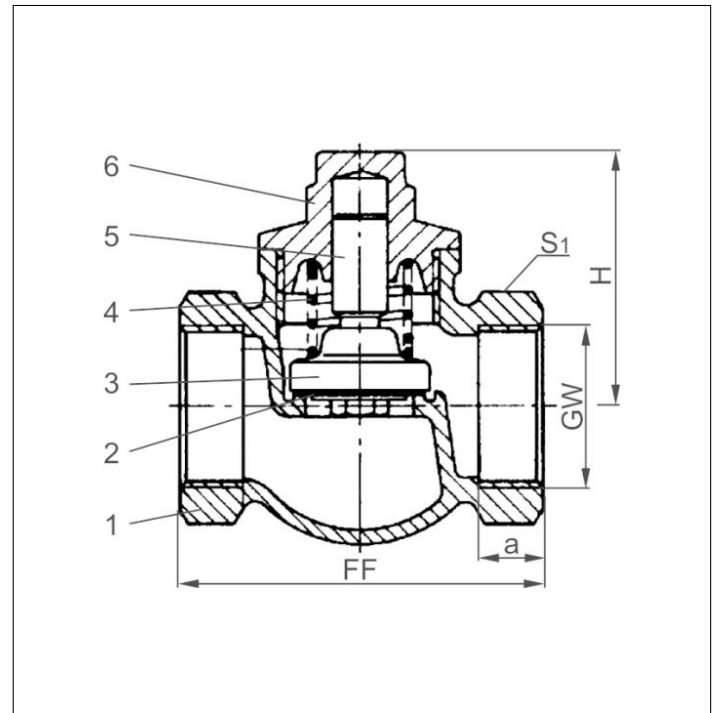

Type 05011 & 05012	Technical data							
Nominal size	GW	3/8	1/2	3/4	1	1-1/4	1-1/2	2
Dimension code	.X.	0300	0400	0600	1000	1200	1400	2000
Face-to-face dimension	FF	50	60	70	80	95	105	130
Height	H	40	40	50	55	55	65	75
Socket depth	a	10	13	14	17	19	19	23
Wrench size across flats	S <sub>1</sub>	22	27	32	41	50	58	70
Weight	ca. kg	0.2	0.3	0.4	0.6	0.9	1.3	2.0

Dimensions in mm.