

Check Valves

Type 05115



Check Valves, PN40

Body in cast steel

seat and disc in stainless steel, metal to metal seated

Part No. 05115.X.0000

Flanged connection acc. to DIN EN 1092-1 PN40

face-to-face dimension acc. to DIN EN 558-1, Reihe 1

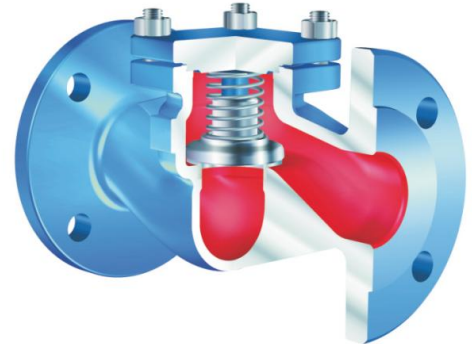

Applications:

Suitable for non-toxic, non-inflammable fluids, gases and vapours.

The laws, regulations and standards are to observe for the range of application.

Working temperatures and pressures:

up to max. 40.0 bar: -10°C / +14°F (263K) up to +120°C / +248°F (393K)

up to max. 33.0 bar: -10°C / +14°F (263K) up to +225°C / +437°F (498K)

up to max. 21.0 bar: -10°C / +14°F (263K) up to +400°C / +752°F (673K)

Materials	DIN EN	ASTM
1 Body	1.0619	A 216 Grade WCB
2 Disc	1.4021	A 276 Grade 420
3 Spring	1.4310	A 313 Grade 301
4 Cap DN15 - 65	1.0402	A 576 Grade 1020
5 Cap DN80 - 150	1.0425	no reference

Essential: When ordering or requesting an offer please indicate flow medium, working pressure and working temperature.

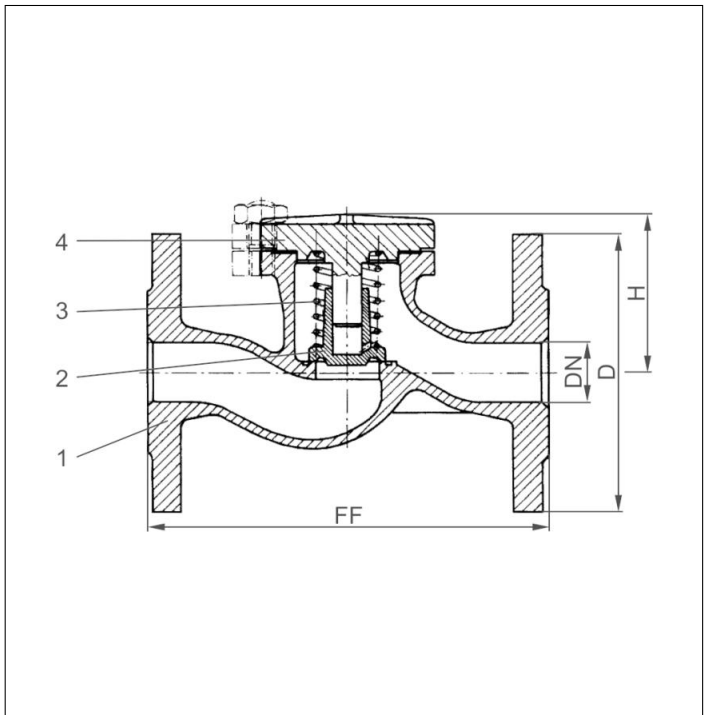

Type 05115	Technical data											
Nominal size	DN	15	20	25	32	40	50	65	80	100	125	150
Dimension code	.X.	0150	0200	0250	0320	0400	0500	0650	0800	1000	1250	1500
Face-to-face dimension	FF	130	150	160	180	200	230	290	310	350	400	480
Height	H	70	70	80	80	85	95	110	130	155	165	215
Flange diameter	D	95	105	115	140	150	165	185	200	235	270	300
Weight	ca. kg	3.8	4.9	5.9	7.1	10.4	12.3	22.7	28.5	40.0	64.0	90.0

Dimensions in mm.