

# Safety Valves

## Type 06317



**Safety Valves, angle type, stainless steel,**  
**type tested, TÜV-SV.847. S/G/L (G 3/8 - G 1/2, d<sub>0</sub> = 6.0 only S/G)**  
**type tested, TÜV-SV.878. S/G/L (G 3/4 - G 1-1/4)**

metal to metal seated, closed bonnet  
 Inlet: male thread type G (BSPP) acc. to ISO 228/1  
 Outlet: female thread type G (BSPP) acc. to ISO 228/1

**Part No. 06317.X.0000**  
 with lifting device - head A

**Part No. 06317.X.0020**  
 with gastight cap - head C

Available options - on request only:  
 · Disc with soft sealing (EPDM, FKM, PTFE)

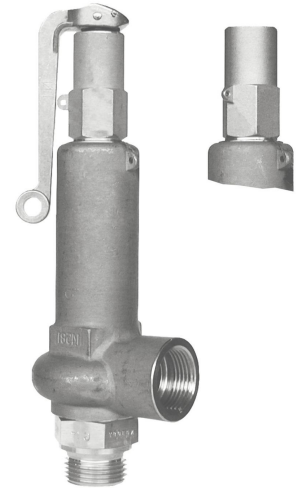

### Applications:

Provided as safety device for protection against excessive pressure in pressure vessels. Approved for gases, vapours and fluids.  
 Working temperature: -60°C / -76°F (213K) up to +280°C / +536°F (553K)

Materials	DIN EN	ASME/ASTM
1 Body + bonnet	1.4581	A 351 CF 10MC
2 Inlet body	1.4571	A 276 Grade 316Ti
3 Disc	1.4571	A 276 Grade 316Ti
4 Stem	1.4571	A 276 Grade 316Ti
5 Spring	1.4310	A 313 Grade 301
6 Lifting cap	1.4581	A 351 CF 10MC
7 Lifting stem	1.4305	A 276 Grade 303
8 Lever	3.2581	no reference
9 Cap	1.4581	A 351 CF 10MC

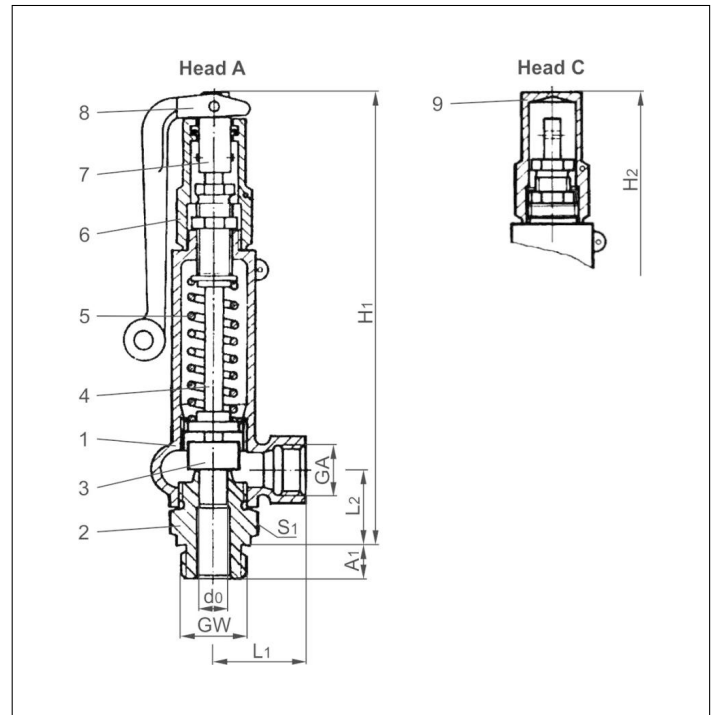

Type 06317	Technical data										
	GW	3/8	1/2	1/2	1/2	3/4	3/4	1	1	1-1/4	1-1/4
Nominal size	d <sub>0</sub>	10	6	8	10	12.5	16	12.5	16	16	20
Dimension code	.X.	1003	0604	0804	1004	1206	1606	1210	1610	1612	2012
Set pressure range	bar	0.1-140	120-500	20-200	0.1-140	32-70	0.1-32	32-70	0.1-32	0.1-32	0.1-20
Outlet	GA	1/2	3/4	1/2	1/2	1	1	1	1	1	1
Height	H <sub>1</sub>	200	200	200	200	230	230	230	230	230	230
Height	H <sub>2</sub>	185	185	185	185	215	215	215	215	215	215
Length	L <sub>1</sub>	40	40	40	40	50	50	50	50	50	50
Length	L <sub>2</sub>	34	34	34	34	40	40	40	40	40	40
Length	A <sub>1</sub>	12	14	12	14	16	16	18	18	20	20
Wrench size across flats	S <sub>1</sub>	32	32	32	32	41	41	41	41	50	50
Weight	ca. kg	1.0	1.0	1.0	1.0	1.6	1.6	1.6	1.6	1.8	1.8
Coeff. of discharge gases, vapours	α <sub>w</sub>	0.38	0.42	0.42	0.38	0.37	0.29	0.37	0.29	0.29	0.11
Coeff. of discharge fluids	α <sub>w</sub>	0.30	-	0.30	0.30	0.29	0.23	0.29	0.23	0.23	0.08

Dimensions in mm.

# Safety Valves

## Type 06317



### Discharge capacities

Calculation of flow rate acc. to AD2000-Merkblatt A2

Medium:

**A = Saturated steam** in kg/h

**B = Air** in m<sup>3</sup>/h at 0°C and 1013.25 mbar

**C = Water** in kg/h at 20°C

The capacity indicated below is for a fully opened valve.

d<sub>0</sub> - orifice

A<sub>0</sub> - flow area

Set pressure in bar (g)	GW	1/2				3/8 & 1/2			3/4 & 1		
	d <sub>0</sub> (mm)	6				10			12.5		
	A <sub>0</sub> (mm <sup>2</sup> )	28.3				78.5			122.7		
	Medium	B	A	B	C	A	B	C	A	B	C
0.1		-	-	-	-	12	15	536	-	-	-
0.4		-	-	-	-	17	24	847	-	-	-
1.0		-	-	-	-	33	40	1257	-	-	-
2.0		-	-	-	-	51	64	1778	-	-	-
3.0		-	-	-	-	68	88	2177	-	-	-
4.0		-	-	-	-	85	110	2514	-	-	-
6.0		-	-	-	-	119	155	3079	-	-	-
8.0		-	-	-	-	152	200	3555	-	-	-
10.0		-	-	-	-	186	245	3975	-	-	-
20.0		-	249	333	3598	351	471	5621	-	-	-
30.0		-	366	494	4406	518	698	6884	-	-	-
35.0		-	425	575	4759	601	812	7436	914	1236	11232
40.0		-	484	656	5088	684	927	7949	1040	1410	12007
50.0		-	602	819	5688	851	1157	8888	1295	1760	13424
60.0		-	722	983	6231	1021	1389	9736	1553	2113	14706
70.0		-	843	1148	6730	1192	1622	10516	1814	2469	15884
80.0		-	968	1314	7195	1368	1858	11242	-	-	-
90.0		-	1096	1482	7632	1549	1549	11924	-	-	-
100.0		-	1225	1650	8044	1731	1731	12569	-	-	-
120.0		1627	1486	1991	8812	2100	2100	13769	-	-	-
140.0		1909	1754	2337	9518	2479	2479	14872	-	-	-
160.0		2182	-	2725	10186	-	-	-	-	-	-
180.0		2455	-	3065	10704	-	-	-	-	-	-
200.0		2782	-	3406	11376	-	-	-	-	-	-
250.0		3541	-	-	-	-	-	-	-	-	-
300.0		4332	-	-	-	-	-	-	-	-	-
350.0		5156	-	-	-	-	-	-	-	-	-
400.0		6019	-	-	-	-	-	-	-	-	-
450.0		6923	-	-	-	-	-	-	-	-	-
500.0		7873	-	-	-	-	-	-	-	-	-

Set pressure in bar (g)	GW	3/4, 1 & 1-1/4			1-1/4		
	d <sub>0</sub> (mm)	16			20		
	A <sub>0</sub> (mm <sup>2</sup> )	201.1			314.2		
	Medium	A	B	C	A	B	C
0.1		23	29	1052	13	16	572
0.4		36	50	1663	19	27	904
1.0		67	81	2467	39	48	1341
2.0		100	127	3489	59	75	1896
3.0		134	171	4273	79	102	2322
4.0		167	215	4934	99	128	2682
6.0		232	303	6043	138	180	3284
8.0		298	391	6978	177	232	3792
10.0		363	479	7801	215	284	4240
20.0		686	920	11033	407	545	5996
30.0		1011	1364	13512	-	-	-
35.0		1174	1587	14595	-	-	-